

An Artificial Neural Network Model for Magnetic Filter Performance

Ismail Saritas, Ilker Ali Ozkan

Department of Electronic and Computer Education
Technical Education Faculty, Selcuk University
Konya Turkey
isaritas@selcuk.edu.tr, ilkerozkan@selcuk.edu.tr

Saadetdin Herdem

Department of Electrical and Electronics Engineering
Engineering and Architecture Faculty, Selcuk University
Konya, Turkey
sherdem@selcuk.edu.tr

Abstract—In this study, a model for the relation between magnetic filter (MF) performance and time was developed by artificial neural network (ANN). The ANN model includes a hidden layer. The input parameters are concentration of magnetic particles in output of MF and time. The output parameter is MF performance. The estimation performance of ANN is evaluated by using sum of squared errors (SSE), correlation coefficient (R^2) and mean relative errors (MRE). The ANN model resulted in a good regression analysis for test data set in which the R^2 is 0.999857, SSE is 0.000132 and MRE is 1.004543. The regression coefficient shows that ANN approach with high level of accuracy can be considered as an alternative and practical technique to estimate performance parameters for MFs. The model enables us to estimate the variable characteristics of filter performance and time used in the cleaning process of industrial liquid. These estimated results provide solutions to be used for the optimization and control of magnetic filtration process and also new filter designs.

Keywords- Artificial neural network; Industrial liquids; Capture magnetic particles; Magnetic filter; Magnetic filter performances

I. INTRODUCTION

There are particles in the composition of industrial liquid and gases. The size of these particles is smaller than a micron ($10\text{-}6\mu$) and their concentration is also very low. Most of the impurities in industrial liquids and gases are reported to possess iron components [1-5], of which some 70–80% consists of magnetite (Fe_3O_4 , $\alpha\text{-Fe}_2\text{O}_3$, nickel, chrome composites etc.) or similar oxides which are magnetic [1, 5]. It is suitable to use Magnetic Filters (MFs) in the cleaning of these particles from industrial liquids and gases [6-8]. MFs are more effective than normal filters and can be operated in high temperatures (700°C) and with greater speed (3 to 10 times faster than normal filters) in hard conditions. MFs, unlike chemical and biological filters, are ecologically harmless [9, 10].

The performance of magnetic filters is expressed as the ratio of the output concentration of particles to their input concentration. This parameter is a function of hydrodynamic parameters of cleaned media and parameters of the magnetic system.

Recently, ANN models have been frequently used in the modeling of natural events.

In this study, an ANN model was developed by experimentally obtained data for estimation of MF performance.

II. MAGNETIC FILTER

One of the effective methods used in the cleaning of industrial liquids and gases is magnetic filtration [8, 9]. MFs are filtration equipment used to clean magnetic particles which are formed by transportation processing in liquid and gas pipelines. As industrial liquids contain iron content substances which are granular shape and ferromagnetic (generally magnetic) character, it is more advantageous to use electromagnetic methods to clean these compositions. In recent years, MFs have been used widely for this purpose [11-15]. The principal difference between MF and classical filters is that porous structure (filter matrix) of MF is made of materials with ferromagnetic character (spheres, sticks, plates, steel rods like wool, metal filings). The principal schema of MF is given in Fig. 1[1, 16].

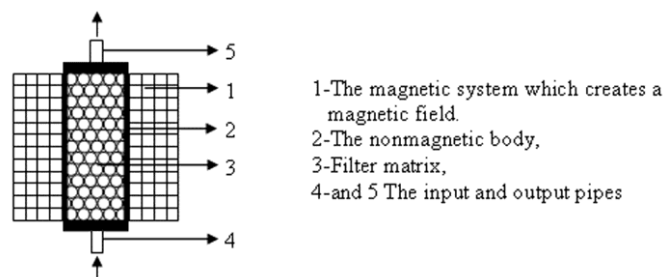

Figure 1. The principle schema of MF

The magnetic system can be composed of electromagnet or magnetic materials (solenoid, toroid, iron-core coil). The body or case is made of non-magnetic and stainless material [14]. When industrial liquids pass through the pores of the filter matrix, magnetic particles in the liquids are captured with the effect of strong magnetic field and accumulated in these fields. Unlike the classical filters -which are characterized with mechanic and hydrodynamic forces- magnetic particles are affected by the greater force in MFs. Therefore, the filtering speed of the liquid for MF is 3 to 10 times higher than that in classical (mechanic) filters. Accordingly, the flow rate or filtration efficiency of the liquid for MF is a few times higher [14].

For the cleaning of industrial liquids in MF, this method is fairly advantageous as a physical method since it does not include any chemical or biological reagents [9]. The physical and chemical characters of liquids that pass through magnetic field do not change. Therefore, MFs, which have a lot of advantages, are used in various fields of industry such as energy production, chemistry, ship building, petrol drilling facilities, wood industry, glass industry, porcelain industry, paper industry and etc.

III. EXPERIMENTAL STUDY

In this study, a MF was designed and set up as seen in the Fig. 2. This mechanism contains the power supply, filter body, coil, ferromagnetic filter component, suspension mixer, pump, control sensors, transporting pipelines, valves and reservoirs. One Ampere of current was applied to the MF coil and a magnetic flux of 0.04 Tesla was obtained. The suspension (1200 liters) was prepared with 10-4 mm sized particles in a reservoir. This suspension was passed through the magnetic filter at a fixed speed (230 l/h). The amounts of particles coming in and out of MF were measured with sensors and then recorded by the computer. The changes in the values versus time are shown in Fig. 3 and Fig. 4.

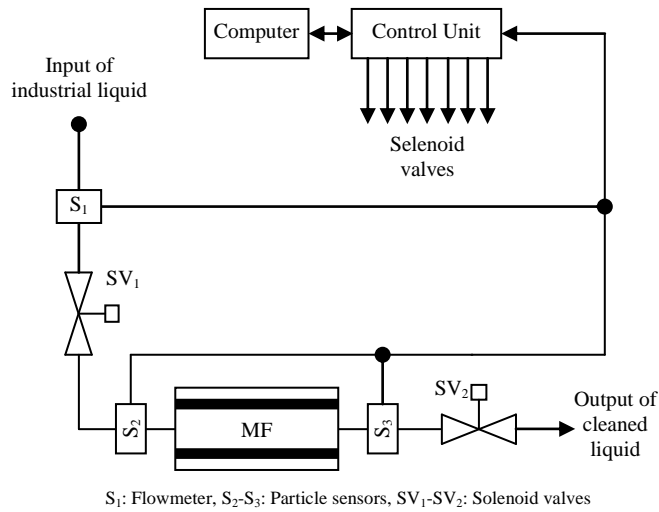

Figure 2. The Designed Filter Mechanism

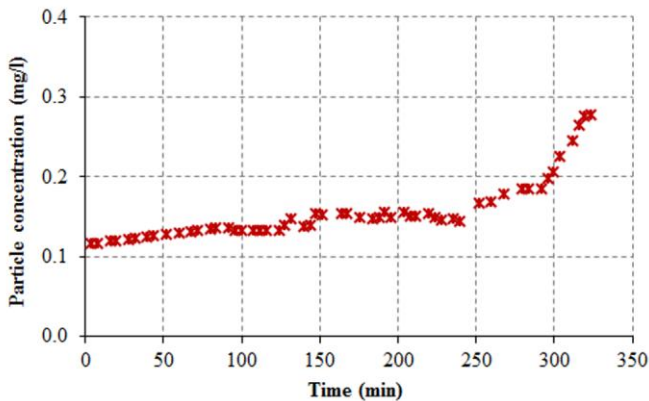

Figure 3. The variation of the input particle concentration in time.

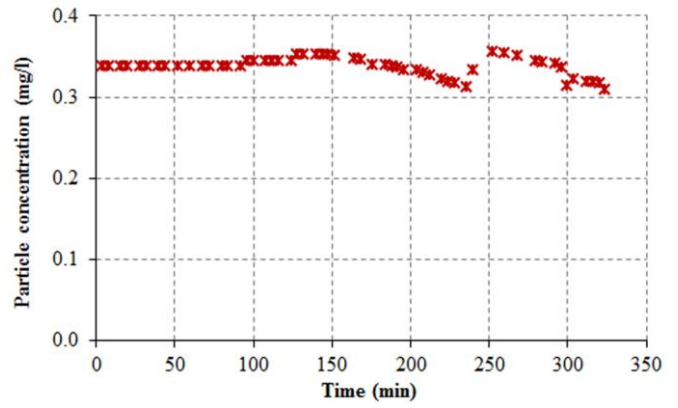

Figure 4. The variation of the output particle concentration in time.

As seen in Fig. 3, the variation in the amount of particles entering to MF is so small to be neglected. The amount of the entering particles was accepted as constant. It is seen in Fig. 4 that the amount of particles that comes out of MF increases in the same period of time. MF performance is defined with the relationship between the incoming and outgoing particle amounts (1). The MF performance obtained in this experimental study was given in Fig. 5 [16].

$$\Psi = 1 - (C_0 / C_i) \quad (1)$$

Where Ψ is filter performance, C_i is concentration of input and C_0 is concentration of output.

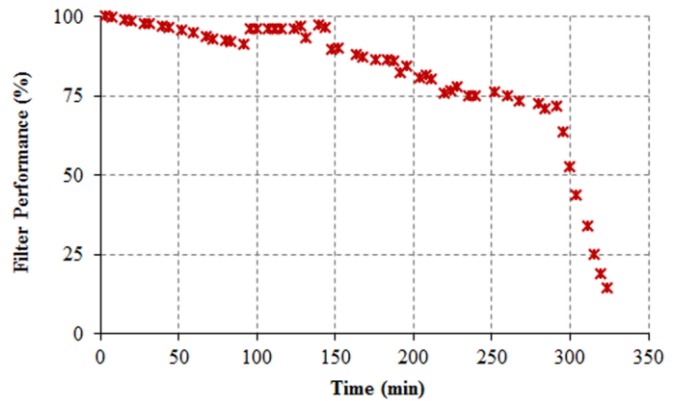

Figure 5. The variation of MF performance in time

IV. ARTIFICIAL NEURAL NETWORK

Artificial Neural Networks (ANN) are computer systems that are developed to have such abilities as automatically generating, forming and discovering new knowledge without any help just as the human brain.

Generally, it is composed of three types of layers; an input layer, a few hidden layers and an output layer. Each layer has a certain number of components called neurons or nodes which are linked to each other. Each neuron is linked to others with communication links accompanied by linking weight. The signals pass through neurons by means of the linking weights. Each neuron takes multiple inputs from other neurons in

accordance with their linking weights and may generate an output signal which can also be generated by other neurons [16, 18].

To develop an ANN model, the network was subjected to two processes; training and test. In training, the network is trained to estimate output values relative to input data. In testing, the network is tested to estimate an output.

When the tested error reaches previously determined tolerance value, the training process is finished [17, 19].

Back Propagation (BP) algorithm is the most popular and most commonly used training algorithm. BP is composed of two phases; feed forwarding and back propagation.

Knowledge subjected to processing from the input layer up to the output layer is generated during feed forwarding. In back propagation phase, the difference between network output value obtained by feed forwarding and desired output value is compared with previously determined error tolerance. This error value is propagated backward to update the links in the input layer [17, 19].

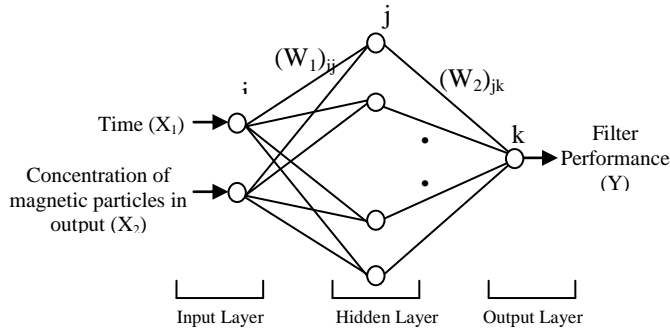

Figure 6. The architecture of ANN

The BP training algorithm is a ramp descent algorithm. BP algorithm minimizes total error by changing the weights through its ramp and thus tries to improve the performance of the network. The training of the network is stopped when the tested values of mean square error (MSE) stop decreasing and begin to increase. The estimated performance is calculated by using (2)-(5) and assessed with MSE, the square sum of errors (SSE), correlation coefficient (R^2) and mean relative error (MRE) values [17, 19].

$$MSE\% = \frac{1}{n} \sum_{i=1}^n (d_i - O_i)^2 \quad (2)$$

$$SSE = \sum_{i=1}^n (d_i - O_i)^2 \quad (3)$$

$$R^2 = 1 - \frac{SSE}{\sum_{i=1}^n O_i^2} \quad (4)$$

$$MRE(\%) = \frac{1}{n} \sum_{i=1}^n \left(100 \times \frac{|d_i - O_i|}{d_i} \right) \quad (5)$$

Where d is the aimed or real value, O is network output or estimated value, n is the number of the output data [17].

V. THE APPLICATION OF ARTIFICIAL NEURAL NETWORK TO EXPERIMENTAL DATA

The aim of proposed ANN model is to estimate the MF performance depending on the amount of input and output particles regarding to MF. The data set obtained from experimental study was divided into two sets as training and test data sets. The experimental data set is composed of 81 values. In ANN training, 55 randomly selected (68% of total data) data set components were used. The remaining 26 (32% of the total data) components were used for performance test.

In this study, a feed forward network with one input layer, one hidden layer and one output layer was used (Fig. 6).

After the ANN structure was developed, the data set obtained in experimental study was normalized in a set containing all values between 0 and 1 to improve training characteristic. In training process, the BP algorithm was used. Tangent-Sigmoid (TANSIG) transfer function was chosen in this study.

The linking weights were randomly prepared for the first use at the beginning of the training process. In the training process, the learning ratio (α) and training speed (β) coefficients were both chosen as 0.3.

The network was trained till it reached the error which is defined as the mean squares of the differences between target output and an acceptable network output. In this study MSE was chosen as 1×10^{-4} . If MSE is bigger than 1×10^{-4} , all the input data are studied again till the network's MSE reaches the desired tolerance. In addition to error value's reaching the desired tolerance, the network is stopped when the desired epoch number reached to the error value.

The estimated ANN performance was assessed by using MSE, SSE, MRE and R^2 . The proposed ANN model was implemented by Matlab (Release 2011b) Neural Network Toolbox.

The ANN parameter values; for example, learning level, moment coefficient, the number of neurons in the hidden layer were chosen according to MSE (Fig. 7).

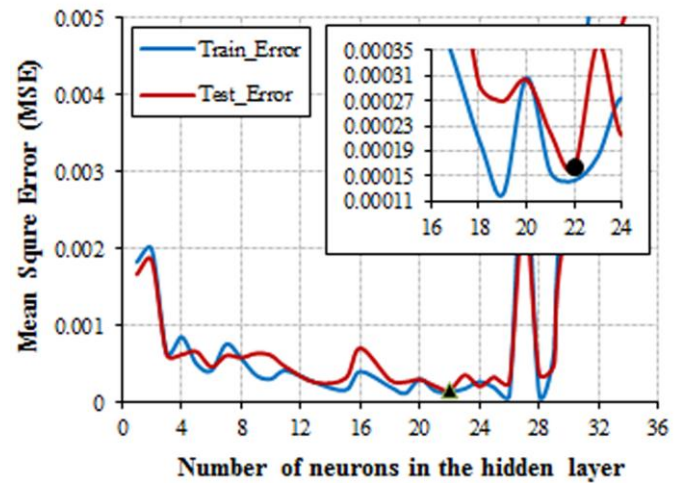

Figure 7. Determination of optimal neurons number in the hidden layer

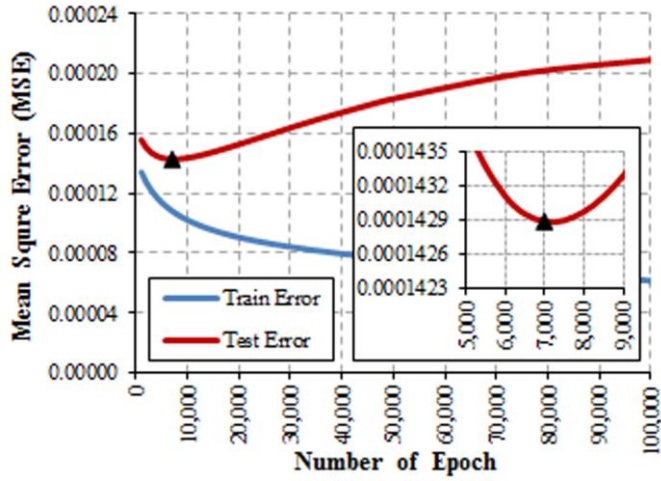

Figure 8. The most suitable epoch number with 22 neurons in the hidden layer relative to MSE

The most suitable neuron number for the hidden layer can be obtained by trying various networks. The number of neurons in the hidden layer was determined by trial and error method by increasing 1 to 50. SSE, MRE and R^2 values are shown Fig. 7. for different networks. Thus, feed forward ANN with 2-22-1 networks architecture was chosen since it has best performance regarding to the error.

To obtain the most suitable epoch number for optimum neuron number in the hidden layer of the designed ANN, epochs from 1 to 100000 were tried. After these trials, the most suitable epoch number with MSE of the ANN performance was determined. Thus, the most suitable epoch number for ANN was determined as 7000 (Fig. 8).

As a result of the investigation, an optimum ANN with 2-22-1 neurons and 7000 epoch was designed. With the help of the designed ANN, estimated values of MF were obtained. The MF performance results obtained from ANN and experimental MF performance data were compared in time (Fig. 9, Fig. 10).

The best approach with minimum error is made with BP algorithm of 22 neurons in the hidden layer. A formula was developed by using the approach (6). To calculate MF performance (Ψ) used in this study, equation (5) was used.

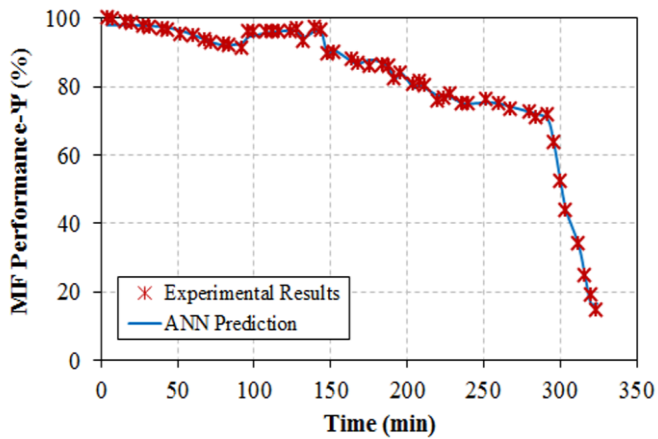

Figure 9. The comparison of the ANN training data and experimental data

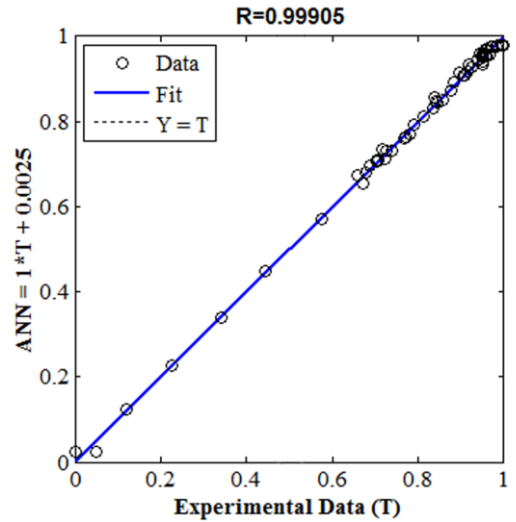

Figure 10. Comparison of experimentally results and ANN-predicted values of MF Performance for the training data set.

TABLE I. CONNECTION WEIGHT VALUES FOR (8).

Number of neurons	W_1 for X_1	W_2 for X_2
1	-9.3832	-9.1173
2	5.7024	11.9300
3	-12.7850	2.7627
4	4.9620	-12.1600
5	-8.2388	-10.3150
6	-8.2748	-9.9440
7	0.8268	-13.0900
8	10.8740	7.2873
9	11.0290	7.1667
10	-12.9100	-2.6235
11	10.9380	-7.2809
12	-13.1250	0.4853
13	11.0600	7.2054
14	3.8583	12.5880
15	10.9220	7.5632
16	-8.1039	10.3270
17	5.0544	12.2100
18	-13.2080	-0.5245
19	-0.8914	13.0750
20	4.6892	-12.2640
21	-12.3050	4.5900
22	-1.0572	13.0910

$$\psi = \left[\frac{2}{1 + \exp(-2 \times (-0.26703 \times F_1 - 0.32882 \times F_2 + 0.058482 \times F_3 - 0.067535 \times F_4 - 0.14298 \times F_5 + 0.39983 \times F_6 + 0.1214 \times F_7 + 0.028076 \times F_8 - 0.050192 \times F_9 + 0.13084 \times F_{10} + 0.51059 \times F_{11} - 0.090555 \times F_{12} + 0.063474 \times F_{13} + 0.12802 \times F_{14} - 0.35229 \times F_{15} - 0.43831 \times F_{16} - 0.24969 \times F_{17} + 0.60916 \times F_{18} - 0.02269 \times F_{19} + 0.18629 \times F_{20} + 0.050638 \times F_{21} - 0.084437 \times F_{22}))} \right] - 1 \quad (6)$$

The transfer function used here is the TANSIG transfer function given in (7).

$$F_j = \frac{2}{1 + e^{(-2 \times NET_j)}} - 1 \quad (7)$$

Here for (6) NET_j was given as related to X_1 and X_2 in (8).

$$NET_j = (W_1)_{i,1} \times X_1 + (W_1)_{i,2} \times X_2 \quad (8)$$

Here the fixed values whose BP algorithm of 22 neurons was $(W_1)_{i,j}$ are given in Table I. In the equation (8), NET_j is the sum of the multiplication products of the input parameters and their weights. The subscripts i and j are input and hidden neuron numbers, respectively. Here, time (X_1) and concentration of magnetic particles in output (X_2) are two input parameters. In ANN, 22 hidden neurons were used. Therefore, 22 equation parts ranging from NET_1 - NET_{22} and F_1 - F_{22} were used as sum and activation functions, respectively.

VI. RESULTS AND DISCUSSION

In this study, an ANN model was developed to estimate MF performance. The comparison of experimental values versus values of formed by ANN are given in Fig. 9. Besides, to assess the accuracy of ANN estimations, the regression curve is shown in Fig. 10.

ANN's estimation performance was assessed with regression analysis between estimated and experimental data. In order to prove ANN model's estimation, sum of squared errors (SSE), correlation coefficient (R^2) and mean relative error (MRE) were considered. The correlation coefficient, sum of squared errors, and mean relative errors were calculated as 0.99888, 0.000212, 1.189080, respectively (Table II). SSE, R^2 and MRE have acceptable values.

TABLE II. STATISTICAL RESULTS OF THE TRAINING DATA SET

	MSE	SSE	R^2	MRE
MFP	0.000108	0.000212	0.999888	0.011891

The comparison of experimental measurement values for MFP test data set and ANN estimation values are shown in Fig. 11. All the randomly selected data used for test is different than the data used for training process.

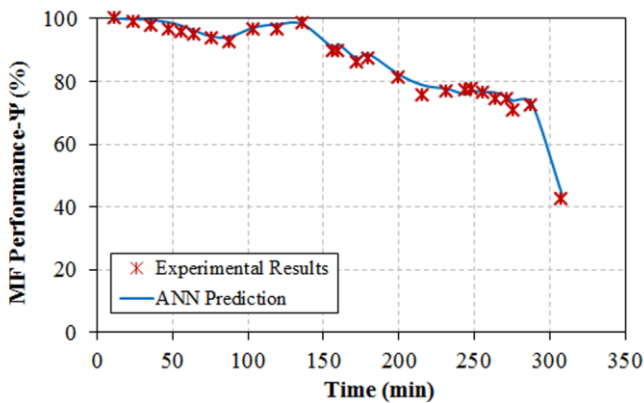

Figure 11. The comparison of ANN test estimation values and Experimental data in terms of time

The regression graphic between the estimated ANN values and experimental measurement values for MF performance is shown in Fig. 12. As the correlation coefficients get closer to 1, estimation accuracy increases. In the case presented in this study, the correlation coefficients obtained are very close to 1, which indicates a perfect match between ANN estimation values and experimental measurement values.

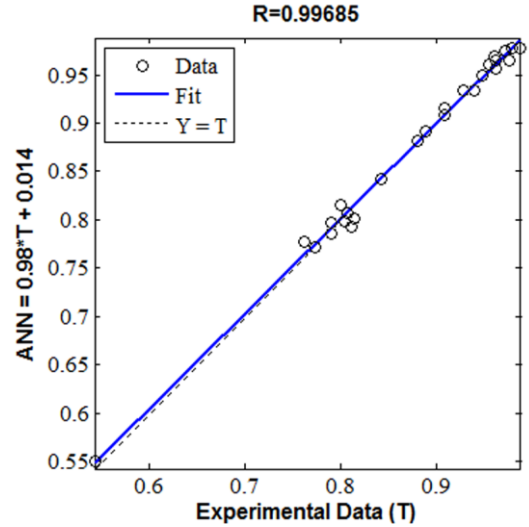

Figure 12. Comparison of experimentally results and ANN-predicted values of Magnetic Filter Performance for the test data set

In the calculations for ANN estimation test data set, the correlation coefficient (R^2) is 0.999857, SSE is 0.000132 and MSE is 1.004543 (Table III). SSE, R^2 and MRE have acceptable values.

TABLE III. STATISTICAL RESULTS OF THE TESTING DATA SET

	MSE	SSE	R^2	MRE
MFP	0.000142	0.000132	0.999857	0.010046

As seen in the figures, the estimation results and experimental results are almost overlapping. The deviation between experimental and estimated results is very small and negligible for any MF performance.

Also the experimental and estimated results were evaluated by t-test for the precision and reliability of the obtained model.

TABLE IV. T-TEST FOR EQUALITY OF MEANS

t	df	Significance (t)	Mean Diff.	Std. Error Diff.	95% Confidence Interval of the Difference	
					Lower	Upper
0.012	108	0.990	0.0466	3.9001	-7.6839	7.7772

Besides, according to the result of the t-test performed within 95% reliability range in SPSS statistical analysis software, there is no significant difference between ANN estimation values and experimental results. They can stand for

each other with high and reliable significance levels as high as 99% as seen in Table IV.

VII. CONCLUSIONS

This paper presents an ANN application used for MF performance estimation in accordance with the amount of magnetic particles in an industrial liquid that comes out of MF in relation to time. In this study, whether an ANN model can be used for MF performance estimation or not is demonstrated.

A feed forward ANN model that has 2-22-1 architecture and BP training algorithm was developed. The estimation performance of ANN is evaluated by using SSE, R^2 and MRE. The ANN model resulted in a good regression analysis for test data set in which the correlation coefficient is 0.999857, sum of squared errors is 0.000132 and mean relative errors is 1.004543. The developed ANN estimated MF performance within an error margin of $\pm 5\%$. The regression coefficient shows that ANN approach with high level of accuracy can be considered as an alternative and practical technique to estimate performance parameters for MFs.

As seen from the results, the proposed ANN model has sufficient accuracy rate for the estimation of MF performance. It is seen that, ANN can be used for modeling of MFs. This study helps engineers and producers in industry to determine MF performance easily without the carrying out extensive experiments. Thus, time and money are being saved.

ACKNOWLEDGEMENTS

This study has been supported by Selcuk University's Scientific Research Unit (BAP) and TUBITAK: The Scientific and Technological Research Council of Turkey (Project number: 109E037).

REFERENCES

- [1] I. Saritas, I. A. Ozkan, S. Herdem, "The effects of fuzzy control of magnetic flux on magnetic filter performance and energy consumption." *Expert Systems with Applications*, 37(12), 2010, pp.7542-7551.
- [2] T. Abbasov, "Sedimentation of the iron particles in rheological liquids with nonhomogenous magnetic field." Doctoral Dissertation. Azerbaijan Academy of Science, Baku, 1991.
- [3] C. De Latour, H. H. Kolm, "High gradient magnetic separation. A water treatment alternative". *J. Am. Water Works Assoc.*, vol. 68, 1976, pp.325-327,.
- [4] K. Harding, W. Baxter, "Application of high gradient magnetic separation to ferric hydroxide filtration." *IEEE Trans. Magn.*, vol. 17(6), 1981, pp.2795-2797.
- [5] T. Abbasov, "Magnetic filtration with magnetized granular beds: Basic principles and filter performance" *China Particuology*, vol. 5(1-2), 2007, pp. 71-83.
- [6] I. Saritas, I.A. Ozkan, S. Herdem, "Design of Fuzzy Expert System for Magnetic Filter Performance According to Magnetic Field", 5th International Conference on Electrical and Electronics Engineering – ELECO 2007, Bursa, 2007, pp. 401-405,.
- [7] I.A. Ozkan, I. Saritas, S. Herdem, "It is modeling Magnetic Filtering process with ANFIS", *Electric, Electronic, Computer, Biomedical Engineering 12th Congress and Exhibitions–EMO 2007, Eskişehir, 2007*, pp.415-418.
- [8] P. Alizade, T. Abbasov, A. Nayir, "Prospects for The Applications of Magnetic Fluids and Electromagnetic Filters in oil Production." *Quarterly published international journal of environment*, vol.25, 1997, pp.17-18.
- [9] S. Herdem, T. Abbasov, M. Köksal, "The importances of magnetic susceptibility, the particles were captured in magnetic filter." *Electric-Electronic and Computer Engineering 11th National Conference Proceeding, Istanbul, 2005*, vol. 1, pp.44-47.
- [10] T.Abbasov, and B. Rüzgar, "In high gradient fields, it is a method that target to Magnetic Carriers." *Electric-Electronic and Computer Engineering 11th National Conference Proceeding, Istanbul, 2005*, vol.1, pp.99-101.
- [11] H.Okada, T. Tada, A. Chiba, K. Mitsuhashi, T. Ohara, and H. Wada, "High Gradient magnetic Separation for Weakly Magnetized Fine Particles." *IEEE Transactions on Applied Superconductivity*, vol.12, 2002, pp.967-970.
- [12] T.Abbasov, and K. Ceylan, "Filter Performance and Velocity Distribution Relation in Magnetic Filtration of Non-Newtonian Liquids." *Separation Science and Technology*, vol. 34(11), 1999, pp.2177–2189.
- [13] H. G. Haitmann, "Iron oxides in boiles water removed magnetically." *Industrial water engineering*, vol. 12, 1969, pp.31-33.
- [14] T. Abbasov, *Processes of Electromagnetic Filtration*. Seckin Pres: Ankara, 2002.
- [15] M. Köksal, T. Abbasov, and S. Herdem, "Mathematical modeling of the magnetic filtration processes." *International Journal of Applied Electromagnetics and Mechanics*, vol. 18, 2003, pp. 227-234.
- [16] I. Saritas, "The Design of Magnetic Filter for Cleaning Industrial Liquids and Adaptive Control of Filter by Artificial Intelligence Methods" Phd Thesis, Selcuk University Institute of the Natural and Applied Sciences, 2008.
- [17] S. A. Kalogirou, "Artificial neural networks in the renewable energy systems applications: a review" *Renewable and Sustainable Energy Reviews*, vol. 5, 2001, pp. 373-401.
- [18] H. Kurt, K. Atik, M. Ozkaymak, and A. K. Binark, "The artificial neural networks approach for evaluation of temperature and density profiles of salt gradient solar pond." *Journal of the Energy Institute*, vol. 80 (1), 2007, pp.46-51.
- I. H. Yang, M. S. Yeo, and K.W. Kim, "Application of artificial neural network to predict the optimal start time for heating system in building." *Energy Conversion and Management*, vol. 44(17), 2003, pp.2791-2809.